

***TB 9-4910-556-35**

SUPERSEDED COPY DATED 12 JULY 1993

DEPARTMENT OF THE ARMY TECHNICAL BULLETIN

CALIBRATION PROCEDURE FOR STE-M1/FVS TEST SET

Headquarters, Department of the Army, Washington, DC

22 January 1996

Approved for public release; distribution is unlimited

REPORTING OF ERRORS

You can help improve this publication by calling attention to errors and by recommending improvements and stating your reasons for the recommendations. Your letter or DA Form 2028, Recommended Changes to Publications, should be mailed directly to Commander, U.S. Army Aviation and Missile Command, ATTN: AMSAM-TMD-EP, Redstone Arsenal, AL 35898-5000. FAX to DSN 788-2313 (commercial 256-842-2313). A reply will be furnished directly to you.

		Paragraph	Page
SECTION	I. IDENTIFICATION AND DESCRIPTION		
	Test instrument identification.....	1	2
	Forms, records, and reports.....	2	2
	Calibration description	3	3
	II. EQUIPMENT REQUIREMENTS		
	Equipment required.....	4	4
	Accessories required	5	5
	III. CALIBRATION PROCESS FOR VEHICLE TEST METER (VTM)		
	Preliminary instructions.....	6	6
	Equipment setup.....	7	6
	Dc voltage.....	8	7
	Resistance	9	8
	Dc current	10	10
	Ac current	11	12
	Ac voltage and frequency.....	12	14
	Pressure	13	15
	Vacuum	14	17
	RPM	15	17

*This bulletin supersedes TB 9-4910-556-35, dated 12 July 1993.

TB 9-4910-556-35

		Paragraph	Page
SECTION	IV. CALIBRATION PROCESS FOR CONTROLLABLE INTERFACE BOX (CIB)		
	Preliminary instructions.....	16	19
	Equipment setup.....	17	19
	10 volt channel check.....	18	21
	Differential voltage	19	21
	100 millivolt channel check	20	22
	Zero volt stimulus	21	22
	+9.5 and -9.5 volt stimulus	22	23
	Frequency	23	24
SECTION	V. CALIBRATION PROCESS FOR SET COMMUNICATOR (SC)		
	Preliminary instructions.....	24	24
	Equipment setup.....	25	25
	Dc voltage.....	26	25
	Ac voltage and frequency.....	27	26
	Resistance	28	27
	Dc current.....	29	27
	Ac current	30	28
	Final procedure.....	31	28

**SECTION I
IDENTIFICATION AND DESCRIPTION**

1. Test Instrument Identification. This bulletin provides instructions for the calibration of STE-M1/FVS Test Set. TM 9-4910-751-14-1 and TM 9-4910-751-14-2 were used as the prime data sources in compiling these instructions. The complete test set will be referred to as the TI (test instrument) throughout this bulletin.

a. Model Variations. Some set communicators do not have a multimeter function. There are three different set communicators being used and as many cable configurations needed to connect them. Use cable or cable combination supplied with TI.

b. Time and Technique. The time required for this calibration is approximately 6 hours, using the dc and low and physical techniques.

2. Forms, Records, and Reports

a. Forms, records, and reports required for calibration personnel at all levels are prescribed by TB 750-25.

b. Adjustments to be reported are designated (R) at the end of the sentence in which they appear. When adjustments are in tables, the (R) follows the designated adjustment. Report only those adjustments made and designated with (R).

3. Calibration Description. TI parameters and performance specifications which pertain to this calibration are listed in table 1.

Table 1. Calibration Description

Test instrument parameters	Performance specifications
Vehicle test meter (VTM)	
Dc voltage	Range 0 to 0.5V dc Accuracy: $\pm 6\%$ of FS Range 0.5 to 4.5 V dc Accuracy: $\pm 3\%$ of FS Range: 4.5 to 45 V dc Accuracy: $\pm 1\%$ of FS
Resistance	Range: 0Ω to 3000Ω Accuracy: $\pm(3\%$ of indication $+0.3\%$ of FS) Range: 3000Ω to $40,000\Omega$ Accuracy: $\pm(3\%$ of indication $+0.5\%$ of FS)
Dc current ¹	Range: 0 to 20 A dc Accuracy: $\pm 7\%$ of input $\pm 2\%$ of FS Range: 0 to 150 A dc Accuracy: $\pm 7\%$ of input $\pm 0.7\%$ of FS Range: 0 to 1500 A dc Accuracy: ± 7 to 8% of input $\pm 0.5\%$ of FS
Ac current (frequency range: 40 to 500 Hz)	Range: 5 to 70 A Accuracy: $\pm(7.0\%$ of indication $+2.0\%$ of FS) Range: 70 to 700 A Accuracy: $\pm 7.0\%$ of indication $+0.65\%$ of FS)
Ac voltage (frequency range: 10 to 500 Hz)	Range: 0 to 35 V Accuracy: $\pm(4.0\%$ of indication $+0.5\%$ of FS)
Frequency	Range: 40 to 500 Hz Accuracy: $\pm 7\%$ of input $\pm 0.65\%$ of FS
Pressure	Range: 0 to 25 psia 0 to 1000 psia Accuracy: $\pm(2.5\%$ of indication $+1.5\%$ of FS)
Vacuum	Range: 0 to 30 inHg Accuracy $\pm 3.5\%$ of input $\pm 1.5\%$ of FS
RPM	Range: 50 to 5000 rpm Accuracy: $\pm 0.5\%$ of FS
Controllable interface box	
10 V channel	Range: 9.5 V dc Accuracy: ± 0.2 V
10 V differential	Range: 9.5 V dc Accuracy: ± 0.2 V
Frequency	Range: 400 Hz Accuracy: ± 20 Hz

See footnote at end of table.

Table 1. Calibration Description - Continued

Test instrument parameters	Performance specifications
Controllable interface box - continued	
100 mV channel	Range: 0 to 100 mV dc Accuracy: ± 5 mV
0 V stimulus	Range: 0 V dc Accuracy: ± 0.083 V
9.5 V stimulus	Range: 9.5 V dc Accuracy: ± 0.2 V
VTM voltage probe	Range: 24 V dc Accuracy: ± 1.2 V
Set communicator	
Dc voltage	Range: 0.000 to 1.999 V Accuracy: $\pm(1.0\%$ of indication $+0.2\%$ of FS) Range: 2.00 to 19.99 V Accuracy: $\pm(1.2\%$ of indication $+0.1\%$ of FS) Range: 2.0 to 1999.9 V Accuracy: $\pm(1.2\%$ of indication $+0.1\%$ of FS)
Ac voltage (frequency range: 30 to 500 Hz)	Range: 0.00 to 0.299 V displayed as 0.000 V 0.030 to 1.399 V Range: 1.40 to 13.99 V Accuracy: $\pm(1.6\%$ of indication $+0.3\%$ of FS) Range: 14.0 to 140.0 V Accuracy: $\pm(1.6\%$ of indication $+0.3\%$ of FS)
Frequency (voltage level: 1.0 to 400 V p-p)	Range: 40.00 to 999.9 Hz Accuracy: $\pm 0.1\%$ of FS Resolution: 0.1 Hz
Resistance	Range: 0.000 Ω to 0.099 k Ω Accuracy: $\pm(2.0\%$ of indication $+1.0\%$ of FS) Range: 0.100 to 19.99 k Ω Accuracy: $\pm(2.0\%$ of indication $+0.0\%$ of FS) Range: 20.00 to 999.9 k Ω Accuracy: $\pm(3.0\%$ of indication $+0.0\%$ of FS)
Dc current	Range: 0.000 to 2.000 A Accuracy: $\pm(1.5\%$ of indication $+0.4\%$ of FS)
Ac current (frequency range: 30 to 500 Hz)	Range: 0.000 to 1.400 A Accuracy: $\pm(1.8\%$ of indication $+0.8\%$ of FS)

¹Maximum error 7% up to 1000 A, increasing linearly to 8% at 1500 A.

SECTION II EQUIPMENT REQUIREMENTS

4. Equipment Required. Table 2 identifies the specific equipment to be used in this calibration procedure. This equipment is issued with Secondary Transfer Calibration Standards Set AN/GSM-287. Alternate items may be used by the calibrating activity. The items selected must be verified to perform satisfactorily prior to use and must bear evidence of current calibration. The equipment must meet or exceed the minimum use specifications listed in table 2. The accuracies listed in table 2 provide a four-to-one ratio between the standard and TI.

5. Accessories Required. The accessories listed in table 3 are issued as indicated in paragraph 4 above and are used in this calibration procedure. When necessary, these items may be substituted by equivalent items, unless specifically prohibited.

Table 2. Minimum Specifications of Equipment Required

Common name	Minimum use specifications	Manufacturer and model (part number)
AMMETER CALIBRATOR	Range: 2 to 4 A Accuracy: $\pm 1.25\%$	Holt, Model 250 (7912648)
CALIBRATOR	Range: 400 Hz	John Fluke, Model 5700A/CT (p/o MIS-35947); w/power amplifier, John Fluke, Model 5215A/CT (5215A/CT); w/transconductance amplifier, John Fluke, Model 5220A/CT (5220A/CT);
DC CURRENT SHUNT	Range: 0 to 75 A Accuracy: ¹	Guildline, Model 9711 (7912323)
DIGITAL MULTIMETER	Range: 0 to 75 mV dc Accuracy: ¹	John Fluke, Model 8506A/CT (p/o MIS-35947 Type 1)
HYDRAULIC PRESSURE STANDARD	Range: 25 to 1000 psig Accuracy: $\pm 1\%$	(MIS-35941)
PNEUMATIC PRESSURE STANDARD	Range: 0 to 25 psig Accuracy: $\pm 0.6\%$	(MIS-30859)
PRECISION OSCILLATOR	Range: 400 Hz Accuracy: $+1.25\%$	Khron-Hite, Model 4100AR-8 (7915951-1) w/amplifier, Khron-Hite, Model 7500RK519 (7915950-1)
RESISTANCE STANDARD	Range: 0 to 40 k Ω Accuracy: 0Ω to $1500\Omega \pm 0.9\%$ 1500Ω to $40,000\Omega \pm 0.85\%$	Biddle-Gray, Model 71-631 (7910328)
SYNTHESIZER/ FUNCTION GENERATOR	Range: 500 Hz Accuracy: $\pm 0.5\%$	Hewlett-Packard, Model 3325A (MIS-35932)

¹Combined accuracy of dc current shunt and digital multimeter: $\pm 1.8\%$ to $\pm 2.1\%$.

Table 3. Accessories Required

Common name	Description (part number)
ADAPTER	Calibration verification adapter (CVA) (12303697)
ADAPTER	(12303696)
ADAPTER	BNC T-type, 2 jacks, 1 plug (MS35173-274C)
CURRENT PROBE	TK11 (supplied with TI)
DC POWER SUPPLY NO. 1	Kepeco, Model HB525M20480 (7915935) Range: 0 to 24 V dc; 5.0 A
DC POWER SUPPLY NO. 2	Dynamic Industries, Model 55314-104054 (MIS-38956)
DC POWER SUPPLY NO. 3	NJE, Model CS36CR30 Range: 0 to 24 V dc; 5.0 A
NITROGEN SOURCE	Compress gas cylinder (7916197)
PNEUMATIC PRESSURE CONTROLLER	(MIS-10324)
PRESSURE REGULATOR	(MIS-10325 Type 1)
VACUUM PUMP	(7912361)

**SECTION III
CALIBRATION PROCESS FOR
VEHICLE TEST METER (VTM)**

6. Preliminary Instructions

a. The instructions outlined in paragraphs **6** and **7** are preparatory to the calibration process. Personnel should become familiar with the entire section before beginning the calibration.

b. Items of equipment used in this procedure are referenced within the text by common name as listed in tables 2 and 3.

c. Unless otherwise specified, verify the result of each test and, whenever the test requirement is not met, take corrective action before continuing with the calibration. Adjustments required to calibrate the TI are included in this procedure. Additional maintenance information is contained in TM 9-4910-751-14-1 and TM 9-4910-751-14-2 for this TI.

d. Unless otherwise specified, all controls and control settings in this section refer to the vehicle test meter (VTM).

7. Equipment Setup

WARNING

HIGH VOLTAGE is used or exposed during the performance of this calibration. DEATH ON CONTACT may result if personnel fail to observe safety precautions. REDUCE OUTPUT(S) to minimum after each step within the performance check where applicable.

a. Connect cable W2 to VTM J4 connector.

b. Connect cable W5 to VTM J1 connector.

c. Connect cable W5 red and black leads to the + (positive) and - (negative) terminals of dc power supply No. 1. Observe polarity.

CAUTION

Throughout this procedure be sure dc power supply No. 1 is adjusted for 24 V dc output before pressing the VTM power switch to **ON** position.

d. Adjust dc power supply No. 1 for 23.5 and 24.5 V dc output.

e. Press power switch to ON position. Verify that TI displays 8.8.8.8. for approximately 2 seconds and then changes to _ _ _ _.

f. Set **TEST SELECT** switches to **66** and press and release **TEST** pushbutton. VTM will display **0066**.

g. Set **TEST SELECT** switches to **99** and press and release **TEST** pushbutton. After several numbers appear (approximately 15 seconds), TI will display, alternately, **PASS** and 4-digit code.

8. Dc Voltage

a. Performance Check

NOTE

If VTM is turned off for any reason, repeat paragraph **7e** through **7g** above.

(1) Connect cable W2 red and black leads (shorted together) to + (positive) connector of dc power supply No. 1.

(2) Set **TEST SELECT** switches to **89**.

(3) Press and hold **TEST** pushbutton until **CAL** appears on VTM. Release **TEST** pushbutton.

(4) Wait for offset value to appear on display. Offset value will be between -6.8 and +6.8.

(5) Press and release **TEST** pushbutton. If VTM does not indicate between -0.03 and +0.03, perform **b(1)** through (9) below.

(6) Connect cable W2 red and black leads to calibrator + (positive) and - (negative) output connections.

(7) Adjust calibrator for 0.5 V dc output. VTM should indicate between 0.47 and 0.53 V dc. Record indication.

(8) Adjust calibrator for 4 V dc output. VTM should indicate between 3.88 and 4.12 V dc. Record indication.

(9) Adjust calibrator for 40.0 V dc output. If VTM does not indicate between 39.60 and 40.40 V dc, perform **b(1)** through (8) and (10) below.

(10) If indications recorded in (7) and (8) above are not within the limits specified, repeat **b(1)** through (10) below until all indications are in tolerance.

b. Adjustments

(1) Disconnect cable W2 from + (positive) connector.

TB 9-4910-556-35

- (2) Set power switch to **OFF** position.
- (3) Remove protective cover of VTM and remove assembly A4, using board removal tool (board holding bracket becomes removal tool).
- (4) Insert extender board into assembly A4 connector and insert assembly A4 into extender board.
- (5) Set power switch to **ON** position.
- (6) Reconnect cable W2 red and black leads to + (positive) connector of power supply.
- (7) Set **TEST SELECT** switches to **89**. Press and hold **TEST** pushbutton until **CAL** is displayed. Release **TEST** pushbutton.
- (8) Press and release **TEST** pushbutton.
- (9) Adjust R10 on assembly A4 for indication between -.03 and +.03 (R).
- (10) Adjust R3 on assembly A4 for indication between 39.60 and 40.40 (R).

9. Resistance

a. Performance Check

- (1) Short cable W2 red and black leads together.
- (2) Set **TEST SELECT** switches to **91**.
- (3) Press and hold **TEST** pushbutton until **CAL** appears on VTM. Release **TEST** pushbutton.
- (4) Wait for offset value to appear on display. Offset value will be between -225 and +225.
- (5) Connect cable W2 red and black leads to resistance standard high and low connectors.
- (6) Press and release **TEST** pushbutton.
- (7) Adjust resistance standard controls until VTM indicates **1400**. If resistance standard does not indicate between 1349.0 Ω and 1451.0 Ω , perform **b(1)** through (11) below.
- (8) Set **TEST SELECT** switches to **92**.
- (9) Short cable W2 red and black leads together.

(10) Press and hold **TEST** pushbutton until **CAL** appears on VTM. Release **TEST** pushbutton.

(11) Wait for offset value to appear on display. Offset value will be between -6.00 and +6.00.

(12) Repeat (5) and (6) above.

(13) Adjust resistance standard controls for 18,000 Ω . If VTM does not indicate between 17.26 and 18.74, perform **b**(1) through (9) and (12) below.

b. Adjustments

(1) Set power switch to **OFF** position.

(2) Set dc power switch to **OFF**.

(3) Open rear panel of VTM and remove assembly A3, using board removal tool.

(4) Insert extender board into assembly A3 connector and insert A3 into extender board.

(5) Set dc power switch to **ON**.

(6) Set power switch to **ON** position.

(7) Set resistance standard for 0.0 Ω .

(8) Repeat **a**(1) through (4) above.

(9) Press and release **TEST** pushbutton.

(10) Set resistance standard controls for 1400 Ω .

(11) Adjust R25 on assembly A3 for display of **1400** on VTM (R).

(12) Set **TEST SELECT** switches to **92** and repeat **a**(3), (4), and (6) above.

(13) Set resistance standard controls for 18,000 Ω .

(14) Adjust R28 on assembly A3 for display of **18.00** on VTM (R).

10. Dc current

a. Performance Check

- (1) Connect equipment as shown in figure 1.

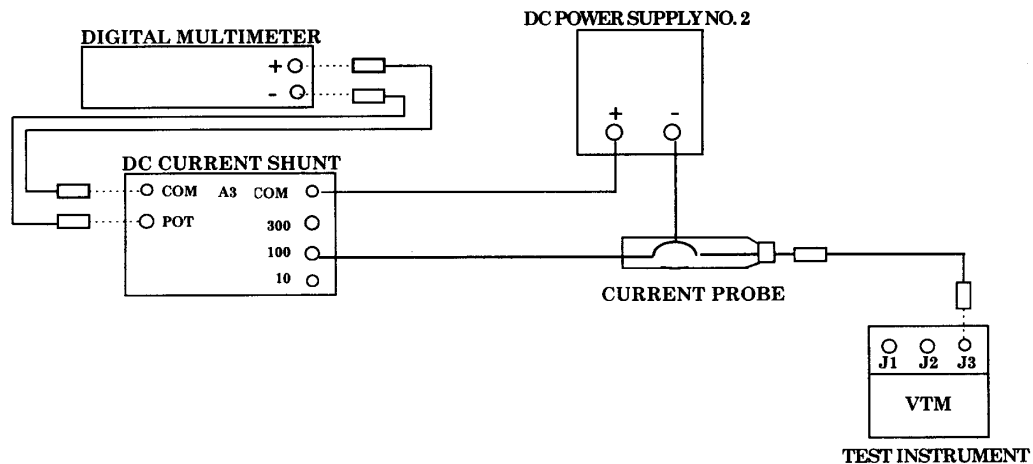

Figure 1. VTM dc current (low) - equipment setup.

NOTE

Clamp current probe on dc power supply No. 2 lead with arrow on probe pointing in the direction of current flow.

- (2) Set dc **ON/OFF** power switch to **OFF** and voltage control to minimum.
- (3) Set **TEST SELECT** switches to **90**.
- (4) Press and hold **TEST** pushbutton until **CAL** appears on VTM display. Release **TEST** pushbutton.
- (5) Wait for offset values to appear on display. Offset values will be between -225 and +225.
- (6) Please shorting plugs in 100 A position on dc current shunt.
- (7) Adjust dc power supply No. 2 for 15 mV (15 A output) on digital multimeter.
- (8) Press and release **TEST** pushbutton. If a - (negative) output occurs, reverse the current probe. VTM should display between 13.55 and 16.45. Record indication.
- (9) Adjust dc power supply No. 2 for 100 mV (100 A output) indication on digital multimeter.

(10) Press and release **TEST** pushbutton. VTM should display between 91.95 and 108.05. Record indication.

CAUTION

While performing this paragraph, minimize the time that current is running through the loop. High current will cause the wire to heat, thus increasing resistance and decreasing the loop current.

(11) Connect equipment as shown in figure 2.

NOTE

Fabricate a current stimulus loop as shown in figure 2. The loop design should be 20 turns of No. 10 insulated copper wire with a bundle diameter of the turns being no more than 1 inch. The inside diameter of the loop should be 6 inches \pm 1 inch. Care should be taken to ensure that the loop does not overheat.

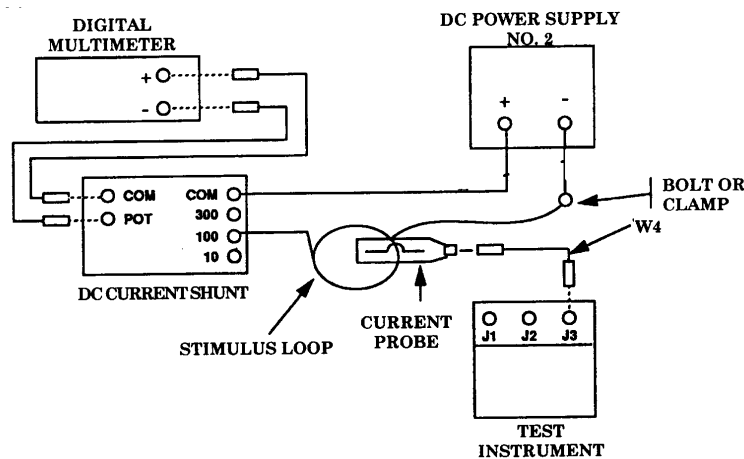

Figure 2. VTM dc current (high) - equipment setup.

NOTE

Clamp current probe to stimulus loop with arrow on probe pointing in direction of current flow.

(12) Adjust dc power supply No. 2 for 25 mV indication on digital multimeter (25 A output).

(13) Press and release **TEST** pushbutton. If a - (negative) output occurs, reverse the current probe. VTM should display between 458 and 543. Record indication.

TB 9-4910-556-35

NOTE

The current probe cannot be opened while the loop is energized due to the induced magnetic field.

(14) Repeat technique of (12) and (13) above for current values and indications shown in table 4. Record indications. If all indications recorded are not within the limits specified, perform **b** below.

Table 4. Dc Current

Digital multimeter indications (mV)	VTM display indications	
	Min	Max
50	923	1078
55	1013	1187
60	1104	1296
65	1195	1406
70	1283	1517
75	1373	1628

b. Adjustments

(1) Peel back decal on top side of probe to expose adjustment access hole.

(2) Adjust full-scale and span adjustments as necessary. Full-scale adjustment is closest to input connector end of current probe.

11. Ac Current

a. Performance Check

(1) Connect equipment as shown in figure 3.

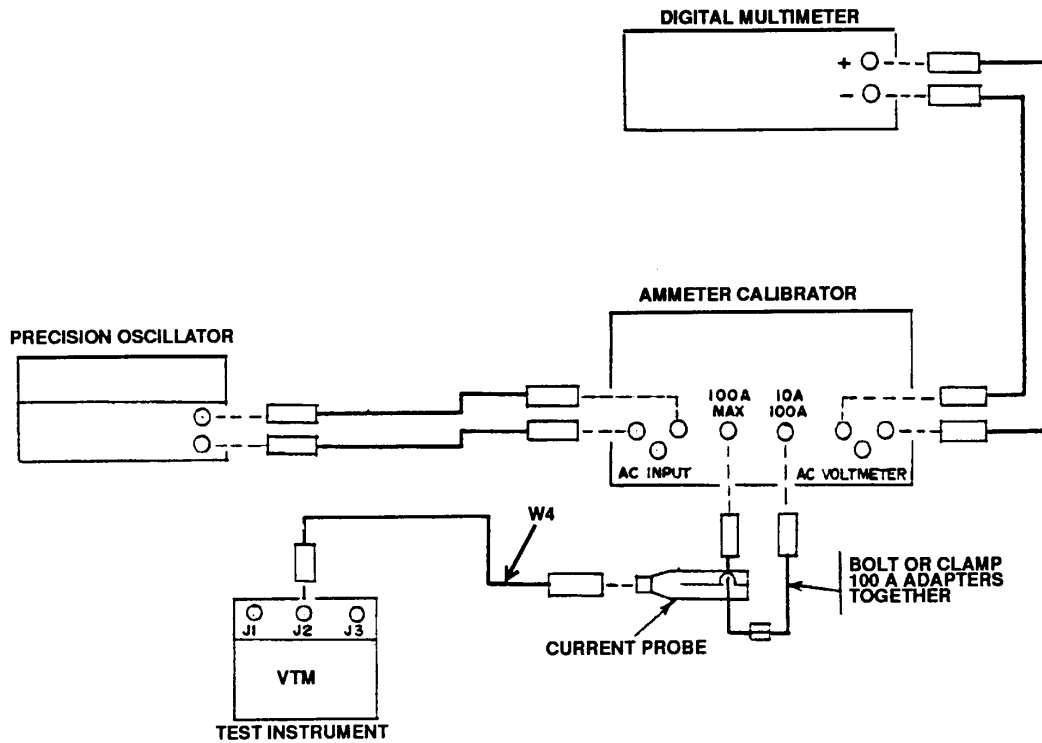

Figure 3. Ac current - equipment setup.

- (2) Set **TEST SELECT** switches to **95**.
- (3) Press and hold **TEST** pushbutton until **CAL** appears on VTM display. Release **TEST** pushbutton.
- (4) Wait for offset values to appear on display. Offset values will be between -225 and +225.
- (5) Set ammeter calibrator for 20 A output.
- (6) Adjust precision oscillator frequency for 400 Hz and voltage output for 1.000 V indication on digital multimeter.
- (7) Press and release **TEST** pushbutton. VTM should display between 17.8 and 22.2. Record indication.
- (8) Set ammeter calibrator for 100 A output.

TB 9-4910-556-35

(9) Adjust precision oscillator frequency for 400 Hz and voltage output for 1.000 V indication on digital multimeter.

(10) Press and release **TEST** pushbutton. VTM should display between 93 and 107 A.

(11) If all indications recorded are not within limits specified, perform **b** below.

b. Adjustments. Perform 10b above. Repeat **10a** above and adjust current probe for in-tolerance indications on ac and dc current.

12. Ac Voltage and Frequency

a. Performance Check

- (1) Connect cable W2 to J4 on VTM.
- (2) Short red and black leads of cable together.
- (3) Set **TEST SELECT** switches to **93**.
- (4) Press and hold **TEST** pushbutton until **CAL** appears on VTM. Release **TEST** pushbutton.
- (5) Wait for offset value to appear on display. Offset value will be between +6.8 and -6.8.
- (6) Connect equipment as shown in figure 4.

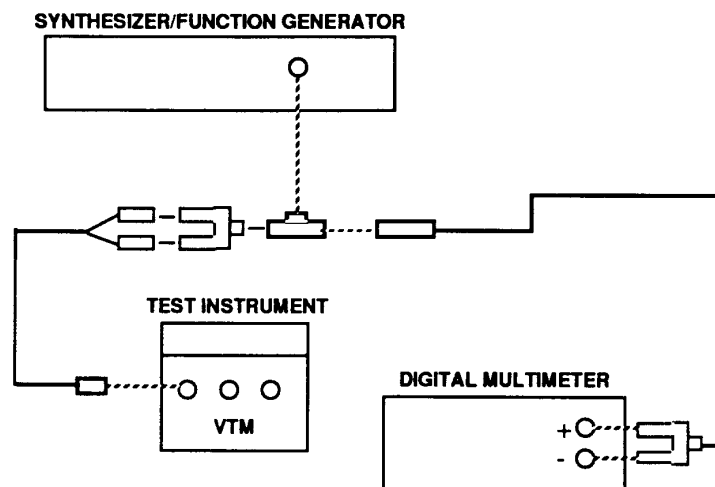

Figure 4. Ac voltage and frequency - equipment setup.

(7) Adjust synthesizer/function generator for 400 Hz indication on frequency counter and 5.0 V rms indication on digital multimeter.

(8) Press and release **TEST** pushbutton on VTM. VTM display will indicate between +4.6 and +5.4.

CAUTION

Do not exceed 35 V ac input to VTM when checking frequency.

(9) Set **TEST SELECT** switches to **96**.

(10) Set synthesizer/function generator for 500 Hz square wave.

(11) Press and release **TEST** pushbutton on VTM. After approximately 10 seconds, VTM will indicate between 461.7 and 538.3.

b. Adjustments. No adjustments can be made.

13. Pressure

a. Performance Check

(1) Connect equipment as shown in figure 5, using 1000 psi transducer TK17 and adapter.

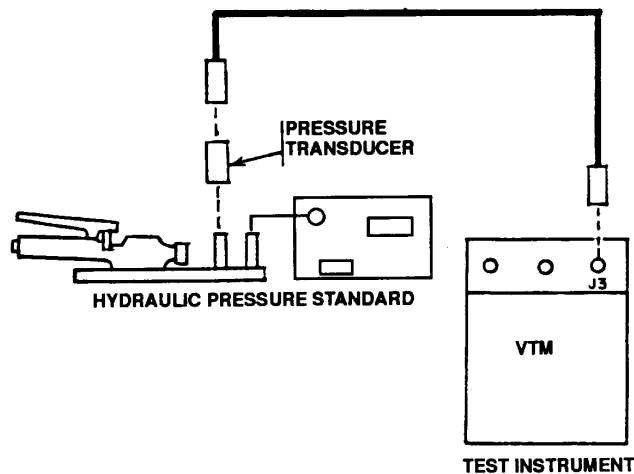

Figure 5. Pressure (1000 psi) - equipment setup.

(2) Set **TEST SELECT** switches to **50**.

(3) Operate hydraulic pressure standard to apply 1000 psi and return to 0 three times.

(4) With pressure at 0, press and hold **TEST** pushbutton until **CAL** appears on VTM display. Release **TEST** pushbutton.

TB 9-4910-556-35

- (5) Wait for offset value to appear on display. Offset value will be between -150 and +150.
- (6) Press and release **TEST** pushbutton.
- (7) Operate hydraulic pressure standard to apply 1000 psi. VTM will indicate between 960 and 1040.
- (8) Operate hydraulic pressure standard to apply 200 psi. VTM will indicate between 180 and 220.
- (9) Connect equipment as shown in CONNECTION A (fig. 6), using pressure transducer TK22, -30 to +25 psig.
- (10) Set **TEST SELECT** switches to **49**.

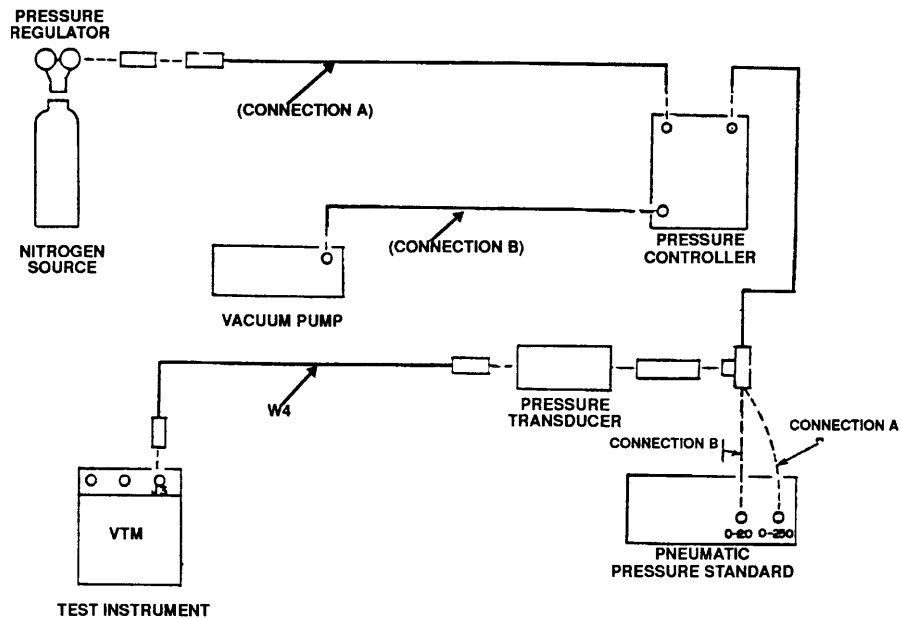

Figure 6. Pressure and vacuum (25 psi) - equipment setup.

- (11) Apply 25 psi and reduce to 0 three times.
- (12) Repeat (4) through (6) above. Offset value will be between -4 and +4.

(13) Apply 5 psi. VTM will indicate between 4.8 and 5.2 psi.

(14) Apply 25 psi. VTM will indicate between 24 and 26 psi.

b. Adjustments. No adjustments can be made.

14. Vacuum

a. Performance Check

(1) To transfer control to VTM, enter **50** on **SET COM** and press **GO** key.

(2) Connect equipment as shown in CONNECTION B (fig. 6), using pressure transducer TK22 -30 to +25 psig.

(3) Set **TEST SELECT** switches to **45**.

(4) Operate vacuum pump and adjust pressure controller and pneumatic pressure standard controls for 18 inHg indication and back to atmospheric pressure three times.

(5) Stop vacuum pump and, with pneumatic pressure standard indicating atmospheric pressure, press and hold **TEST** pushbutton until **CAL** appears on display. Press and release **TEST** pushbutton.

(6) Wait for offset value to appear on display. Offset value will be between -4.5 and +4.5.

(7) Press and release **TEST** pushbutton.

(8) Operate vacuum pump and adjust necessary controls for 18.00 inHg indication on pneumatic pressure standard. VTM will display between 16.9 and 19.1.

b. Adjustments. No adjustments can be made.

15. RPM

a. Performance Check

(1) Connect equipment as shown in figure 7.

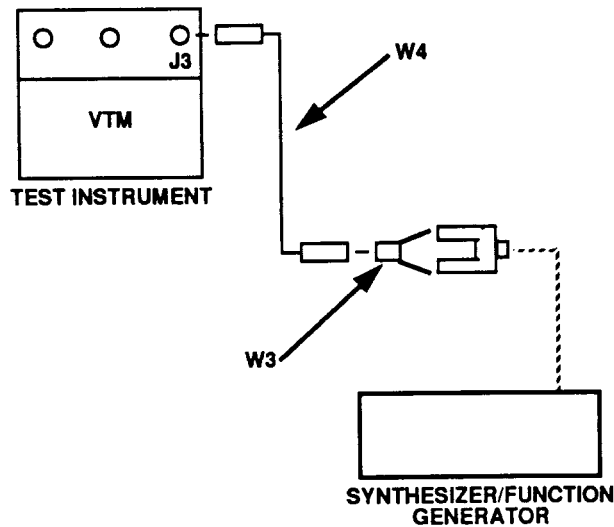

Figure 7. RPM - equipment setup.

- (2) Set **TEST SELECT** switches to **60**.
- (3) Press and release **TEST** pushbutton. Display will indicate **VEH**.
- (4) Set **TEST SELECT** switches to **01**.
- (5) Press and release **TEST** pushbutton. Display will indicate **1**.
- (6) Set **TEST SELECT** switches to **10**.
- (7) Adjust synthesizer/function generator for 0 V output.
- (8) Press and release **TEST** pushbutton. Display will indicate **0**.
- (9) Adjust synthesizer/function generator for square wave (positive pulse) output of 7 to 13 V and 4500 rpm indication on VTM display. Synthesizer/function generator will indicate between 149.1 Hz (6.70 ms) and 150.8 Hz (6.63 ms).
- (10) Repeat technique of (9) above for indications listed in table 5. Synthesizer/function generator will indicate within limits specified.
- (11) Set **VTM** power switch to **OFF**.

b. Adjustments. No adjustments can be made.

Table 5. RPM

VTM display indications	Frequency counter indications			
	Min		Max	
	Hz	ms	Hz	ms
4000	132.50	7.45	134.16	7.54
3000	99.16	9.91	100.83	10.08
2000	65.83	14.80	67.50	15.19
1000	32.50	29.27	34.16	30.76
300	9.16	92.33	10.83	109.17

**SECTION IV
CALIBRATION PROCESS FOR
CONTROLLABLE INTERFACE BOX (CIB)**

16. Preliminary instructions

a. The instructions outlined in paragraphs **16** and **17** are preparatory to the calibration process. Personnel should become familiar with the entire bulletin before beginning the calibration.

b. Items of equipment used in this procedure are referenced within the text by common name as listed in tables 2 and 3.

c. Unless otherwise specified, verify the result of each test and, whenever the test requirement is not met, take corrective action before continuing with the calibration. Adjustments required to calibrate the TI are included in this procedure. Additional maintenance information is contained in TM 9-4910-751-14-1 and TM 9-4910-751-14-2 for this TI.

d. Unless otherwise specified, all controls and control settings in this section refer to the controllable interface box (CIB).

17. Equipment Setup

WARNING

HIGH VOLTAGE is used or exposed during the performance of this calibration. DEATH ON CONTACT may result if personnel fail to observe safety precautions. REDUCE OUTPUT(S) to minimum after each step within the performance check where applicable.

a. Connect equipment as shown in CONNECTION A (fig. 8).

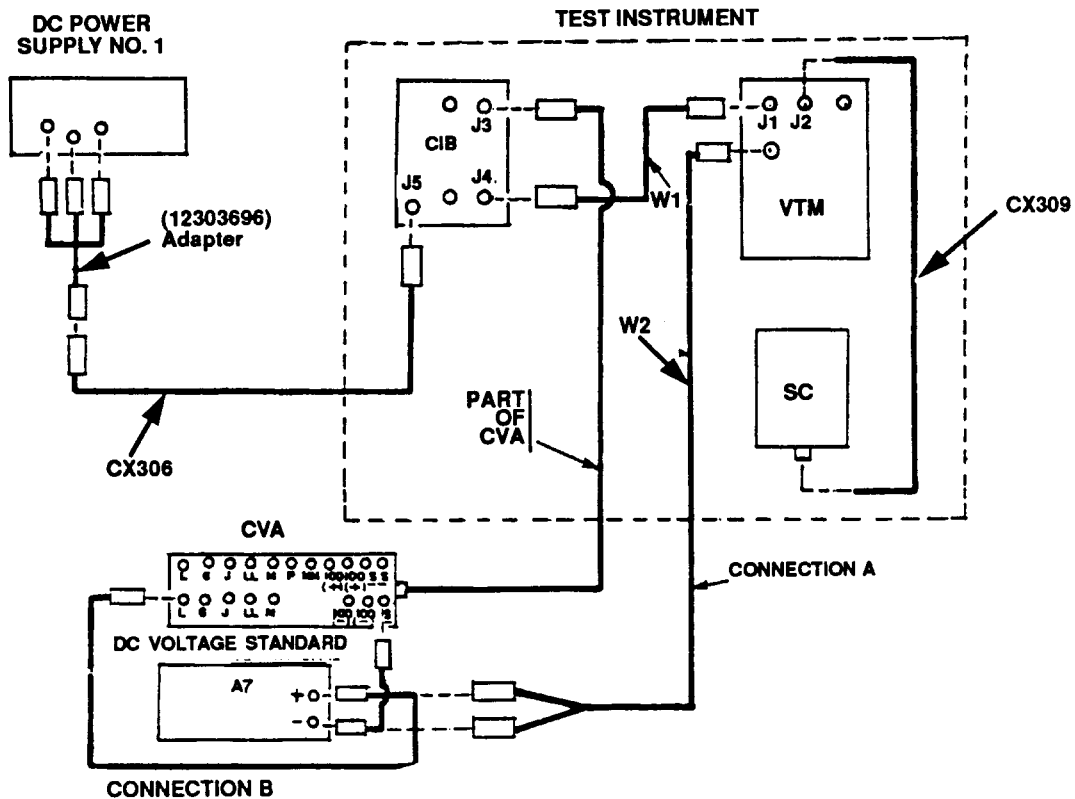

Figure 8. 10 V and 100 mV channel accuracy - equipment accuracy.

- b. Set calibrator to **STANDBY** and 24 V output.
- c. Set **CIB PWR** switch to **ON**.
- d. Press **VTM** power switch to **ON**.
- e. Set **TEST SELECT** switches on VTM to **00**.

NOTE

If set communicator is in **MULTIMETER MODE**, press pushbutton on lower left of set communicator.

- f. Press **TEST** pushbutton on VTM. VTM display should be clear and set communicator should display **STE-M1/FVS CLEAR UNIT**.
- g. Press **CLEAR** key on set communicator. Set communicator will indicate **ENTER TEST NUMBER**.
- h. Set calibrator to **OPERATE**.

i. Using **DATA ENTRY** keys, enter **66668** on set communicator and press **GO** key. Set communicator will display between +22.80 and +25.20 V.

18. 10 Volt Channel Check

a. Performance Check

- (1) Set calibrator to **STANDBY** and +9.500 V output.
- (2) Connect equipment as shown in CONNECTION B (fig. 8).
- (3) Press **STOP** and **CLEAR** key on set communicator.
- (4) Using **DATA ENTRY** keys, enter **66657** on set communicator and press **GO** key.
- (5) Set calibrator to **OPERATE**. Set communicator will indicate between 9.3 and 9.7.
- (6) Set calibrator to **STANDBY**.

b. Adjustments. No adjustments can be made.

19. Differential Voltage

a. Performance Check

- (1) Press set communicator **STOP** and **CLEAR** keys. Set communicator will indicate **ENTER TEST NUMBER**.
- (2) Connect + (positive) output of calibrator to lower G terminal of CVA.
- (3) Connect - (negative) output of calibrator to lower J terminal and guard terminal to upper J terminal of CVA.
- (4) Set calibrator to **STANDBY** and 9.500 V output.
- (5) Using **DATA ENTRY** keys, enter **66663** on set communicator and press **GO** key.
- (6) Set calibrator to **OPERATE**. Set communicator will indicate between 9.300 and 9.700.
- (7) Set calibrator to **STANDBY** and press set communicator **STOP** and **CLEAR** keys.

b. Adjustments. No adjustments can be made.

TB 9-4910-556-35

20. 100 Millivolt Channel Check

a. Performance Check

CAUTION

Do not exceed +97.00 mV output from dc voltage standard in the following steps.

(1) Connect equipment as shown in CONNECTION B (fig. 8), except connect + (positive) lead from dc voltage standard to 100 (+) terminal on CVA and connect – (negative) lead to -100 terminals.

(2) Set calibrator to all zeroes and **OPERATE**.

(3) Using **DATA ENTRY** keys, enter **66659** on set communicator and press **GO** key.

(4) Set output of calibrator to 95 mV. Set communicator will indicate between 90 and 100 mV.

(5) Reduce dc voltage output to 0.

(6) Press set communicator **STOP** and **CLEAR** keys.

(7) Repeat technique of (2) through (6) above for enter codes 66660, 66661, and 66662. Set communicator will indicate between 90 and 100 mV for each entry.

(8) Set calibrator to **STANDBY** and disconnect from adapter.

b. Adjustments. No adjustments can be made.

21. Zero Volt Stimulus

a. Performance Check

(1) Connect – (negative) lead from digital multimeter to S terminal on CVA.

(2) Connect + (positive) lead from digital multimeter to G terminal on CVA.

(3) Using **DATA ENTRY** keys, enter **66664** on set communicator and press **GO** key. Digital multimeter will indicate between -0.083 and +0.083 V.

(4) Press set communicator **STOP** and **CLEAR** keys.

(5) Repeat technique of (2) and (3) above for CVA terminals N, LL, H, P, and MM (fig. 9). Digital multimeter will indicate between -0.083 and +0.083 V at each terminal.

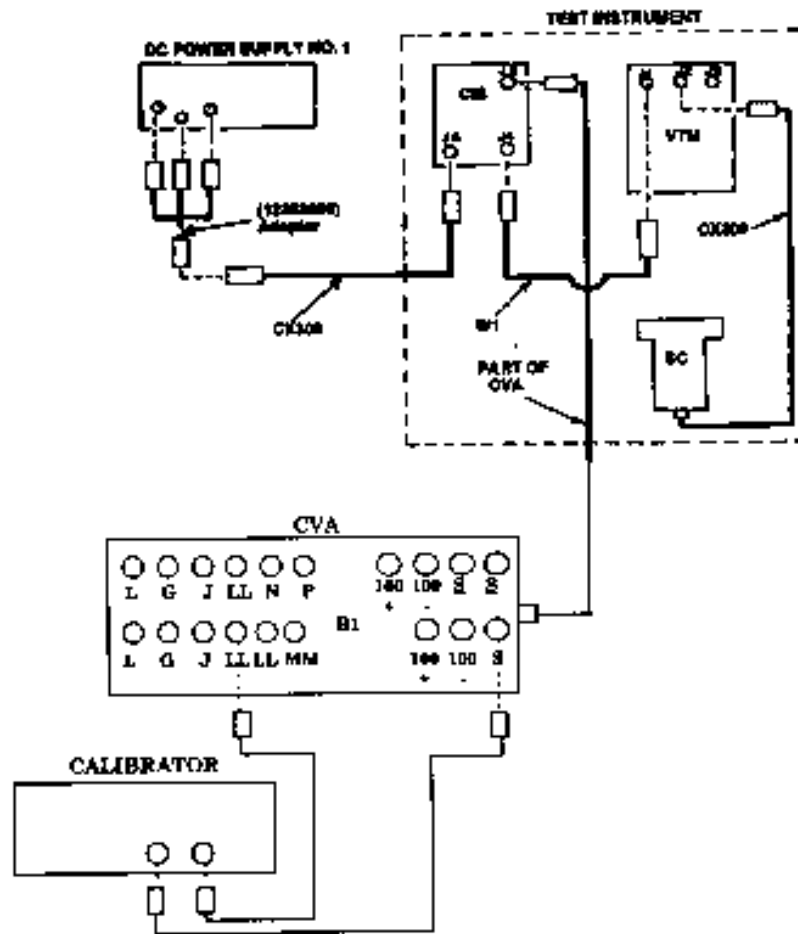

Figure 9. Frequency accuracy - equipment setup.

b. Adjustments. No adjustments can be made.

22. +9.5 and -9.5 Volt Stimulus

a. Performance Check

(1) With - (negative) lead from digital multimeter connected to S terminal on CVA and + (positive) lead connected to G terminal, enter **66665** on set communicator and press **GO** key. Digital multimeter will indicate between +9.15 and +9.85 V.

(2) Repeat technique of (1) above with + (positive) lead from digital multimeter connected to CVA terminals N, LL, H, P, and MM (fig. 9). Indication on digital multimeter will remain between +9.15 and +9.85 V.

(3) Using **DATA ENTRY** keys, enter **66666** on set communicator and repeat (1) and (2) above. Digital multimeter indications will remain between -9.15 and -9.85 V.

TB 9-4910-556-35

(4) Press set communicator **STOP** and **CLEAR** keys. Enter **66664** on set communicator and press **GO** key.

(5) Press set communicator **STOP** and **CLEAR** keys.

b. Adjustments. No adjustments can be made.

23. Frequency

a. Performance Check

(1) Connect equipment as shown in figure 9.

(2) Adjust controls of calibrator for 3 V, 400 Hz output.

(3) Using **DATA ENTRY** keys, enter **66658** on set communicator and press **GO** key. Set communicator will indicate between 380 and 420.

b. Adjustments. No adjustments can be made.

SECTION V CALIBRATION PROCESS FOR SET COMMUNICATOR (SC)

NOTE

This section is applicable only to set communicators which have a multimeter function.

24. Preliminary Instructions

a. The instructions outlined in paragraphs **24** and **25** are preparatory to the calibration process. Personnel should become familiar with the entire section before beginning the calibration.

b. Items of equipment used in this procedure are referenced within the text by common name as listed in tables 2 and 3.

c. Unless otherwise specified, verify the result of each test and, whenever the test requirement is not met, take corrective action before continuing with the calibration. Adjustments required to calibrate the TI are included in this procedure. Additional maintenance information is contained in TM 9-4910-751-14-1 and TM 9-4910-751-14-2 for this TI.

d. Unless otherwise specified, all controls and control settings refer to the set communicator (SC).

25. Equipment Setup

WARNING

HIGH VOLTAGE is used or exposed during the performance of this calibration. DEATH ON CONTACT may result if personnel fail to observe safety precautions. REDUCE OUTPUT(S) to minimum after each step within the performance check where applicable.

- a. Connect cable W2 to set communicator J2 connector and red and black leads to dc voltage standard.
- b. Connect set communicator to VTM J2 connector, using cable CX309 (or CX50 and CX309).
- c. Set **PWR** switch on CIB to **ON** and press **VTM** power switch to **ON**.
- d. Set **TEST SELECT** switches to **00**.
- e. Press **TEST** pushbutton. VTM display should be clear and set communicator should display **STE-M1/FVS CLEAR UNIT**.
- f. Press **CLEAR** key on set communicator. Set communicator will indicate **ENTER TEST NUMBER**.

26. Dc Voltage

a. Performance Check

- (1) Press and release **DMM** switch on SC. SC will display: **MULTIMETER MODE**. Press **STEP** key to change function.
- (2) Press and release **STEP** key. SC will display: **DMM SELF TEST XXXXXX**. Press **GO** key.
- (3) Do not press **GO** key on communicator.
- (4) Set dc voltage standard output to 10.000 V dc.
- (5) Set calibrator to **OPERATE** mode.
- (6) Press and release **STEP** key on SC. SC will display:
DC VOLTAGE.
 Range: 0 to +200 V dc,
 Then: Between +9.680 and +10.320.

TB 9-4910-556-35

- (7) If indication is not between +9.680 and +10.320 V dc, perform **b** below.
- (8) Set calibrator to **STANDBY** mode.

b. Adjustments

- (1) Set calibrator to **STANDBY** and remove cable from J2 on SC.
- (2) Press and release **DMM** switch to turn SC off.
- (3) Remove cover from SC.
- (4) Press and release **DMM** switch to multimeter mode.
- (5) Press **STEP** key twice to dc voltage mode.
- (6) Connect cable to J2 and set calibrator output to 10.000 V dc.
- (7) Adjust R20 on DMM board for 10.0 V dc indication on SC. (DMM board is located underneath computer board. R20 is on far right side of board) (R).

27. Ac Voltage and Frequency

a. Performance Check

- (1) Connect cable W2 red and black leads to calibrator.
- (2) Set calibrator for 10.000 V ac and 100 Hz.
- (3) Set calibrator to **OPERATE** mode.
- (4) Press and release **STEP** key on SC. SC will display:

AC VOLTAGE

Range: 30 mV to 140 V rms

Then: Between 9.42 and 10.58 V rms.

- (5) Press and release **STEP** key on SC. SC will display:

FREQUENCY

Range: 40 to 1000 Hz

Then: Between +99.0 and 101.0 Hz.

- b. Adjustments.** No adjustments can be made.

28. Resistance

a. Performance Check

- (1) Connect cable W2 red and black leads to resistance standard.
- (2) Set resistance standard to 1400Ω.
- (3) Press and release **STEP** key on SC. SC will display:

RESISTANCE

Range: 0 to 1000 kΩ

Then: Between 1.372 and 1.428 kΩ.

b. Adjustments. No adjustments can be made.

29. Dc Current

a. Performance Check

- (1) Connect equipment as shown in figure 10.

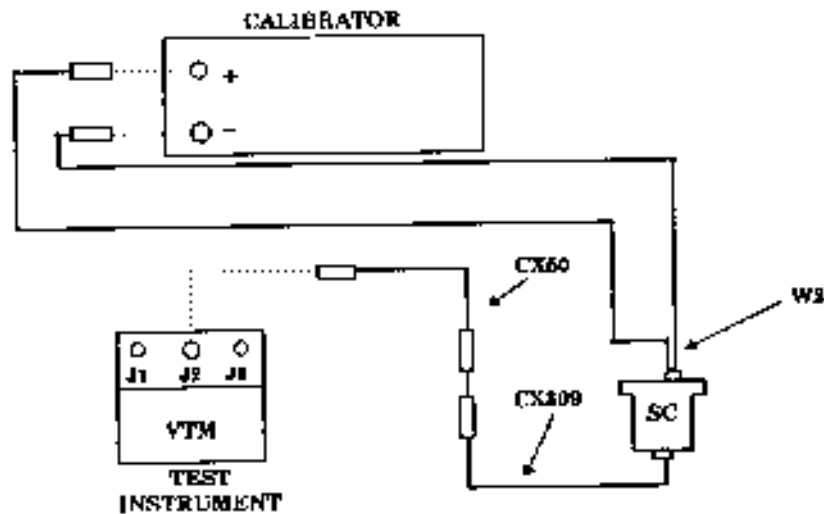

Figure 10. Dc and ac current - equipment setup.

- (2) Press and release **STEP** key on SC. SC will display:

DC CURRENT

Range: 0 to ±2 A dc

Then: ±0.000 A dc

TB 9-4910-556-35

- (3) Set calibrator for 1.5 A dc output.
- (4) Set calibrator to **OPERATE** mode.
- (5) Set communicator will indicate between 1.46 and 1.53 A dc.
- (6) Set calibrator to **STANDBY** mode.

b. Adjustments. No adjustments can be made.

30. Ac Current

a. Performance Check

- (1) Connect equipment as shown in figure 10.
- (2) Press and release **STEP** key on SC. SC will display:

AC CURRENT

Range: 0 to 1.14 A rms

Then: ± 0.000 A ac.

- (3) Set calibrator for 1 A ac, 400 Hz output.
- (4) Set calibrator to **OPERATE** mode.
- (5) Set communicator will indicate between .95 and 1.05 A ac.
- (6) Set calibrator to **STANDBY** mode.

b. Adjustments. No adjustments can be made.

31. Final Procedure

- a.** Deenergize and disconnect all equipment.
- b.** Annotate and affix DA label/form in accordance with TB 750-25.

By Order of the Secretary of the Army:

DENNIS J. REIMER
General, United States Army
Chief of Staff

Official:

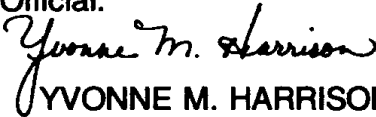
Official:

YVONNE M. HARRISON
Administrative Assistant to the
Secretary of the Army
01362

Distribution:

To be distributed in accordance with DA Form 12-34-E, Block No. 2041, requirements for calibration procedure TB 9-4910-556-35.